



Dr. Silke Bagschik

Head of Sales and Marketing – ID. Family
CMO – ID. Digital

UBS Paris Electric Car Day – April, 12th 2022



Disclaimer



The following presentations as well as remarks/comments and explanations in this context contain forward-looking statements on the business development of the Volkswagen Group. These statements are based on assumptions relating to the development of the economic, political and legal environment in individual countries, economic regions and markets, and in particular for the automotive industry, which we have made on the basis of the information available to us and which we consider to be realistic at the time of going to press. The estimates given entail a degree of risk, and actual developments may differ from those forecast.

At the time of preparing these presentations, it is not yet possible to conclusively assess the specific effects of the latest developments in the Russia-Ukraine conflict on the Volkswagen Group's business, nor is it possible to predict with sufficient certainty to what extent further escalation of the Russia-Ukraine conflict will impact on the global economy and growth in the industry in fiscal year 2022.

Any changes in significant parameters relating to our key sales markets, or any significant shifts in exchange rates or commodities relevant to the Volkswagen Group or the supply with parts, or deviations in the actual effects of the Covid-19 pandemic from the scenario presented will have a corresponding effect on the development of our business. In addition, there may be departures from our expected business development if the assessments of the factors influencing sustainable value enhancement and of risks and opportunities presented develop in a way other than we are currently expecting, or if additional risks and opportunities or other factors emerge that affect the development of our business.

We do not update forward-looking statements retrospectively. Such statements are valid on the date of publication and can be superseded.

This information does not constitute an offer to exchange or sell or an offer to exchange or buy any securities.

ACCELERATE



Our ambition: Responsibility for climate change & society

min. 30%
BEV Share

2025

min 70%
BEV Share

2030

100%
BEV Share

2035

min 50%
BEV Share

2030



ZERO
Volkswagen way to **ZERO**



The massive BEV Ramp-up happens now!

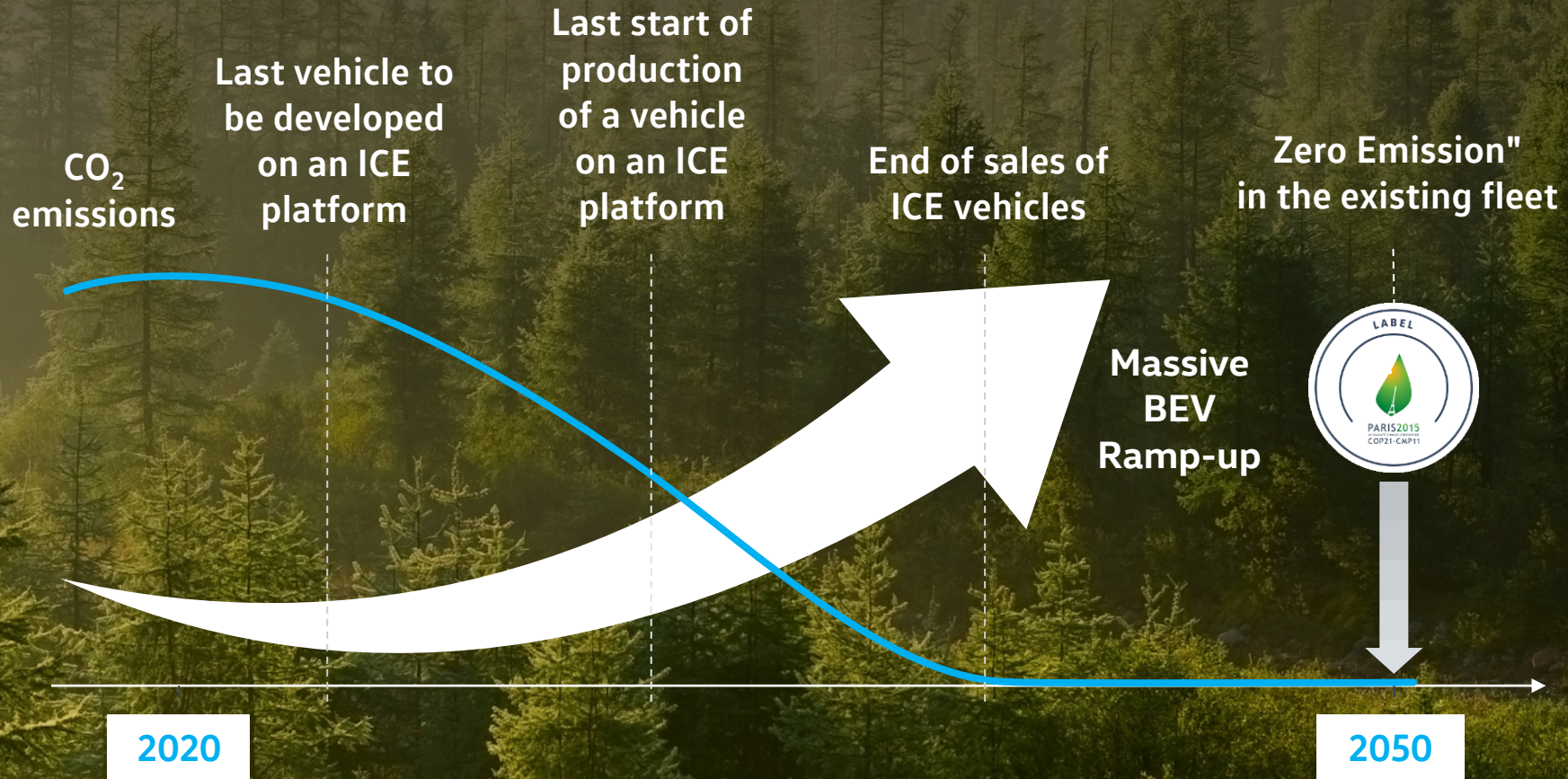

The ID. Family



Volkswagen Design





ID.5



ID.BUZZ



To come: Long Range Business Mobility



To come: Entry mobility



Expansion of our GTX models



GTX



The MEB: Scalable BEV platform



The MEB: The centerpiece of our ID. Family and electrification in the group

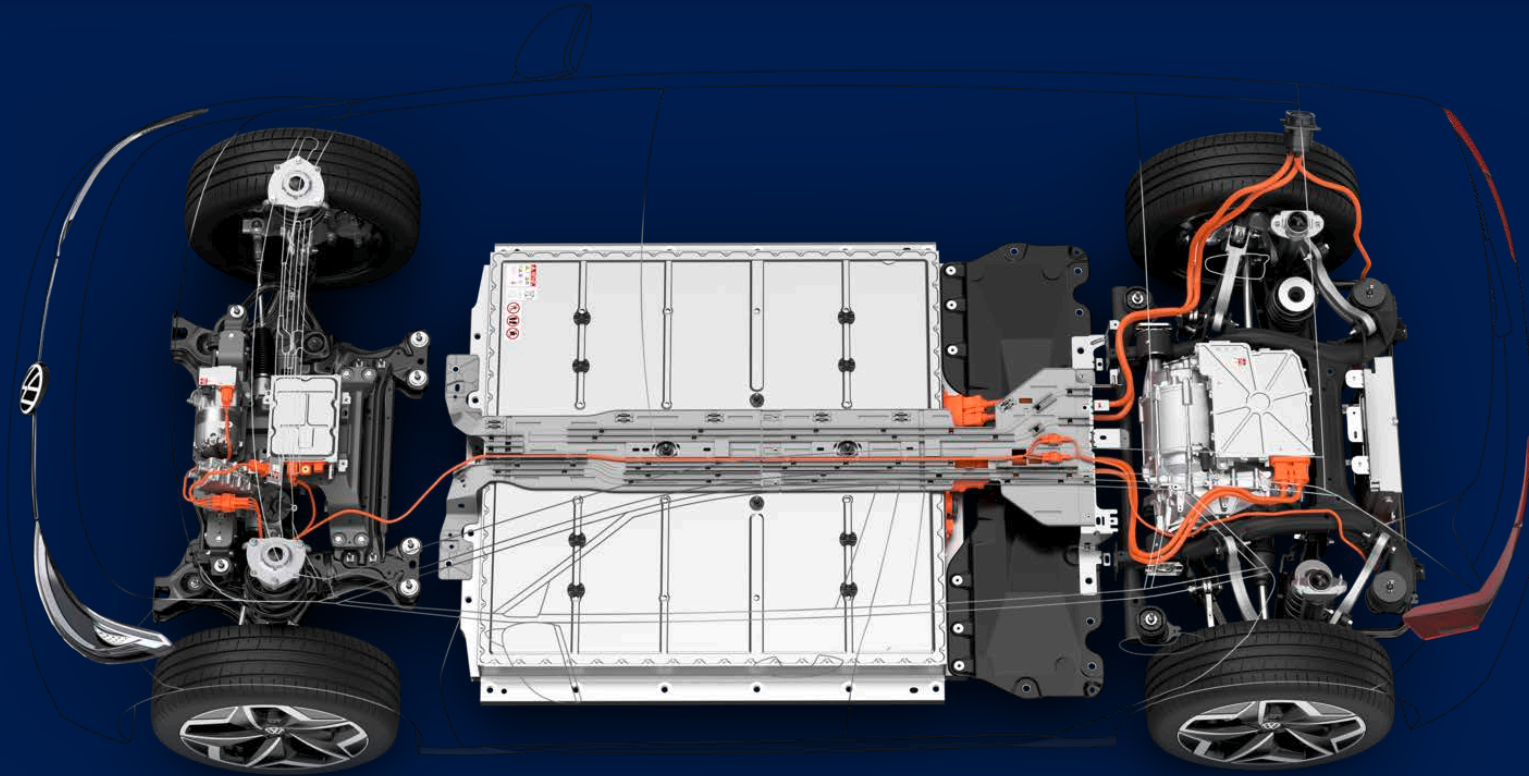

To come: the project Trinity



Our new Scalable Systems Plattform (SSP) will bring autonomous driving into series production



To come: Enhancements in the ID. DNA: What defines our ID. Family

ICONIC
DESIGN



INSPIRING
DIMENSIONS



INTELLIGENT
DATA



INTUITIVE
DEVICE



INFINITE
DRIVE



To come: Enhancements in the MEB platform

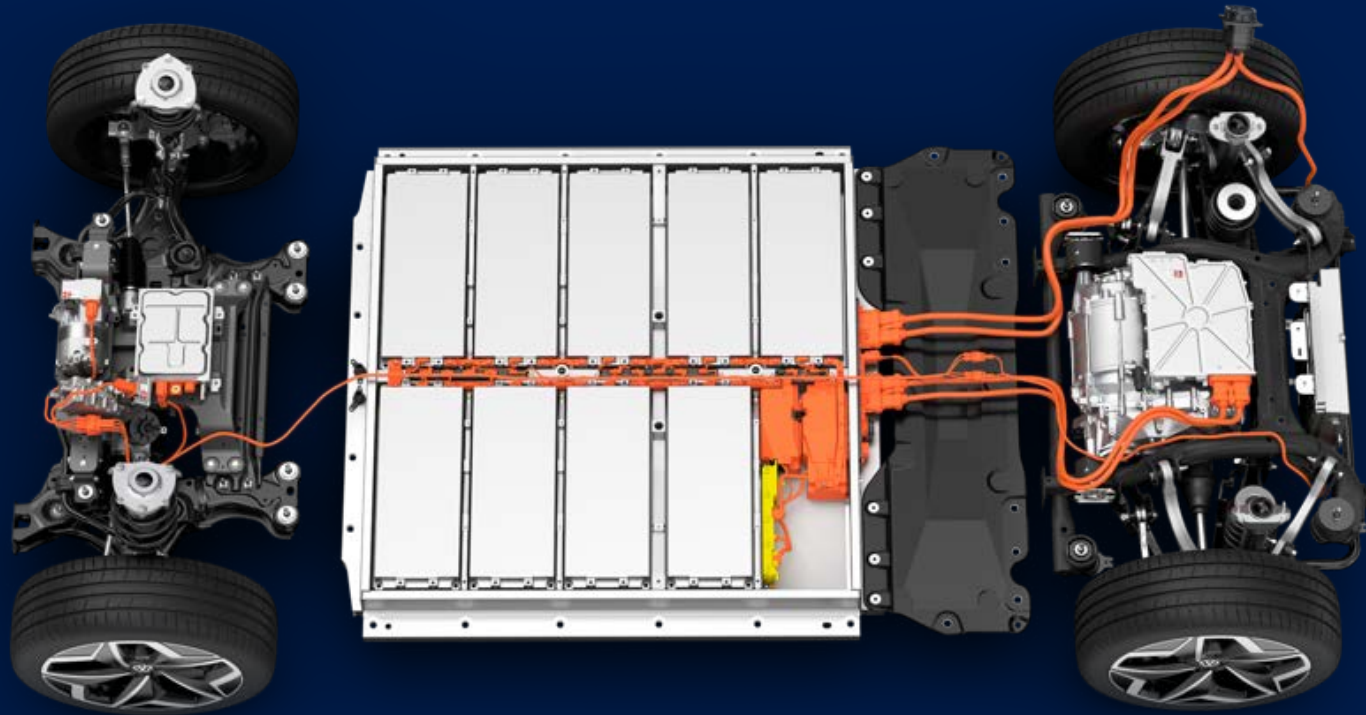

Range

up to 700 km

Charging power

> 200 kW

Acceleration

about 5.5 sec. (w/ AWD)



Our MEB platform electric vehicle portfolio

ID.3



ID.6 X/CROZZ



ID.BUZZ



ID. LIFE 



2020



ID.4



ID.5

2025



AERO B 



To maximize the climate impact of our BEV technology we are open to share with other car manufactures

1 Large range



2 attractive costs



3 maximum security



4 robustness



5 worldwide use



6 long lifespan



7 high performance



8 designed for fast charging

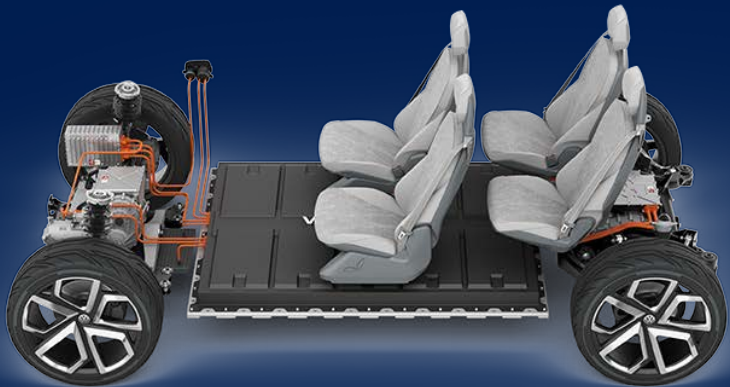

The transformation: software and digitalization



ID. Software 3.0 – extract of highlights



Battery optimization and faster charging



Update for the Augmented-Reality-Head-up-Display



Improvements in voice recognition and performance



Trained Parking (Park Assist Plus)

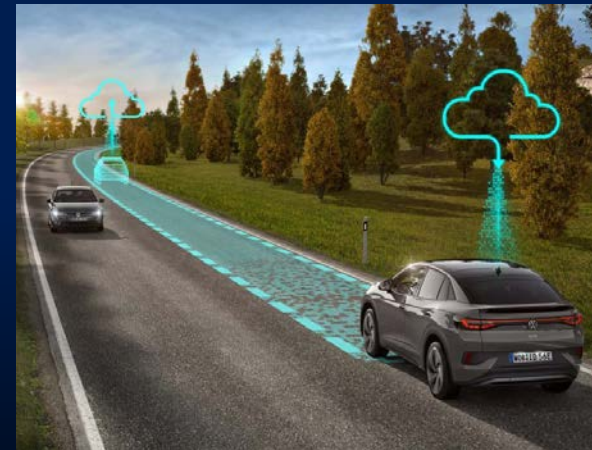

Improvements in navigation – integration of smart data



Ramp-up of Over-the-Air Updates

Global Rollout starting 2022 with US, CN

Continually integration
Regular 3-4x p.a.

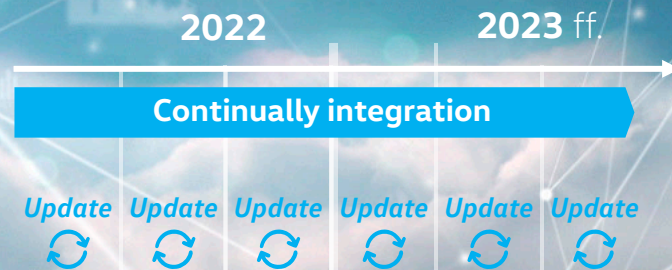

WAVE 1

WAVE 2

WAVE 3

Canary Release –
not all customers at once
but rollout in waves

Increasing Ramp-up of ID. Volume



Becoming a mobility partner for our customers is software enabled



Software enabled interaction

Connected Eco-System: Customer – Car – Volkswagen
-> more speed, direct feedback, ease of interaction

Software enabled continuous improvement

Regular Over-the-Air Updates (incl. firmware)
-> more performance, more features, better usability



Becoming the mobility partner for our customers



Transforming our business model enabled by OTA and data-based matchmaking



Business Model 1.0

Focus on initial purchase of a one-time vehicle configuration



Business Model 2.0

Lifetime monetization of vehicle and (new) services



Pickung up the pace for Business Model 2.0 - Volkswagen car subscription

- ✓ Subscribe to the bestselling ID.3 and ID.4
- ✓ Flexible terms starting from three or six months
- ✓ 800 free kilometres each month
- ✓ ID.3 and ID.4 all-inclusive – the only thing you need to do is charge the car
- ✓ Flexible approach between sharing and leasing
- ✓ Starting from €499.00 per month



ID.3: combined power consumption in kWh/100 km (NEDC): 15.6-13.1,
CO₂ emissions in g/km: 0; efficiency class: A+



AutoAbo

Introducing "ID. Trial" – testing the ID.3 for 30 days



**Functions on Demand allow our customers to
upgrade their vehicles over lifetime.
Coming to the ID. Family this year!**



Part of our Business Model 2.0 - The Volkswagen charging ecosystem

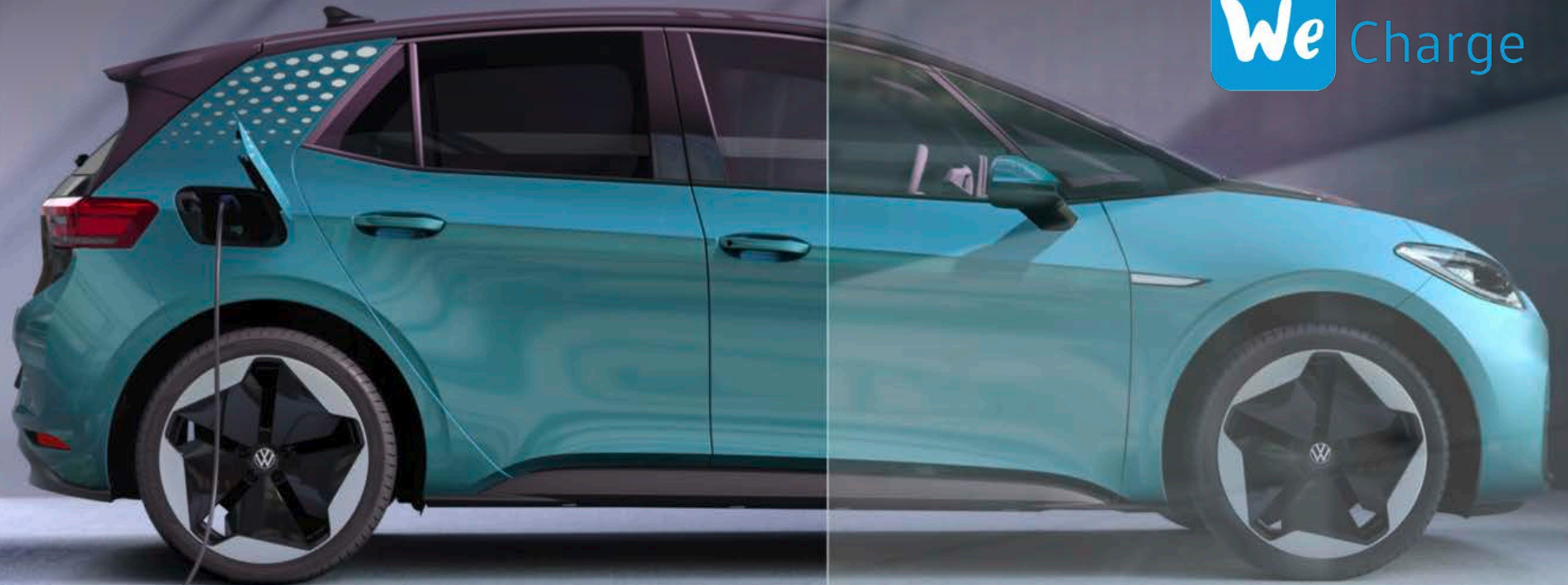

Continuing our *Way to Zero*



All ID.s on their Way to Zero: the automotive supply chain



100 % green energy in battery cell production



Battery

100 % renewable green energy in the Zwickau factory



Assembly

Green energy offer + green energy production to offset use phase



Use

**Green steel
Green aluminum
-> Industry task**

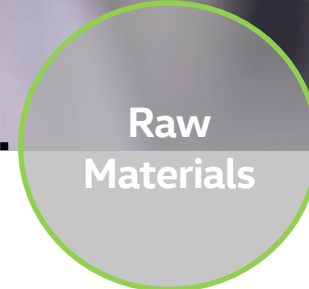

**Raw
Materials**



Certified: All members of our ID. Family in Europe are delivered to customers net carbon neutral

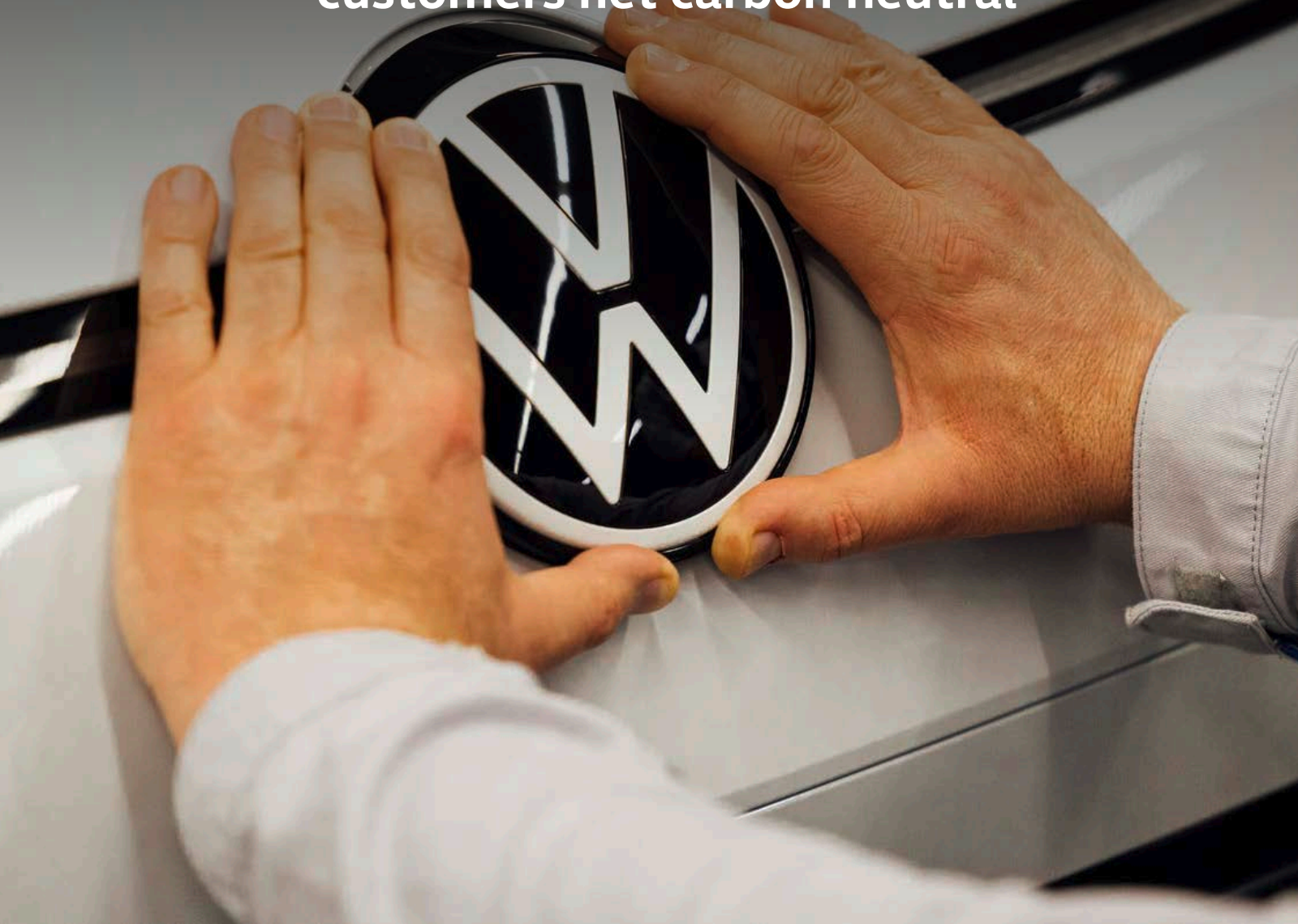

Proud to contribute every day

Mobility for generations to come

